

# MicroRally

## sPDM-620

6 channel simple PDM, 20A total current.

Revision r1

Title: Cover page				MicroRally
Project: sPDM-620				
PCB: r1	BOM: v1	Sheet 1 of 9	Size: A4	Engineer: Andis Zile
File: Cover_page.SchDoc				Date: 10.04.2024

# Index

Page	Title
1	Cover page
2	Index
3	Diagram
4	Power
5	Inputs
6	Outputs
7	Controller
8	Miscellaneous
9	Revision History

Title: Index				<b>MicroRally</b>
Project: sPDM-620				
PCB: r1	BOM: v1	Sheet 2 of 9	Size: A4	Engineer: Andis Zile
File: Index.SchDoc				Date: 10.04.2024

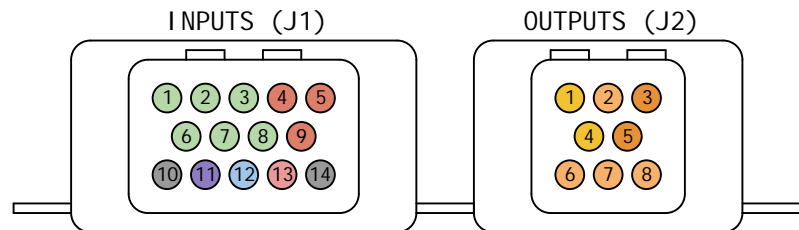

INPUTS (J1)

1	IN1	Digital input 1
2	IN2	Digital input 2
3	IN3	Digital input 3
4	VBAT	Battery power input
5	VBAT	Battery power input
6	IN4	Digital input 4
7	IN5	Digital input 5
8	IN6	Digital input 6
9	VBAT	Battery power input
10	GND	Ground
11	5VOUT	5V Output
12	OD1	Fault indicator and reset
13	OD3	Ignition (Enable) power input
14	GND	Power ground

OUTPUTS (J2)

1	OUT1	Output 1
2	OUT2	Output 2
3	OUT3	Output 3
4	OUT1	Output 1
5	OUT3	Output 3
6	OUT4	Output 4
7	OUT5	Output 5
8	OUT6	Output 6

Title: Diagram

Project: sPDM-620

PCB: r1

BOM: v1

Sheet 3 of 9

Size: A4

File: Diagram.SchDoc

Date: 10.04.2024

MicroRally

Engineer: Andis Zile

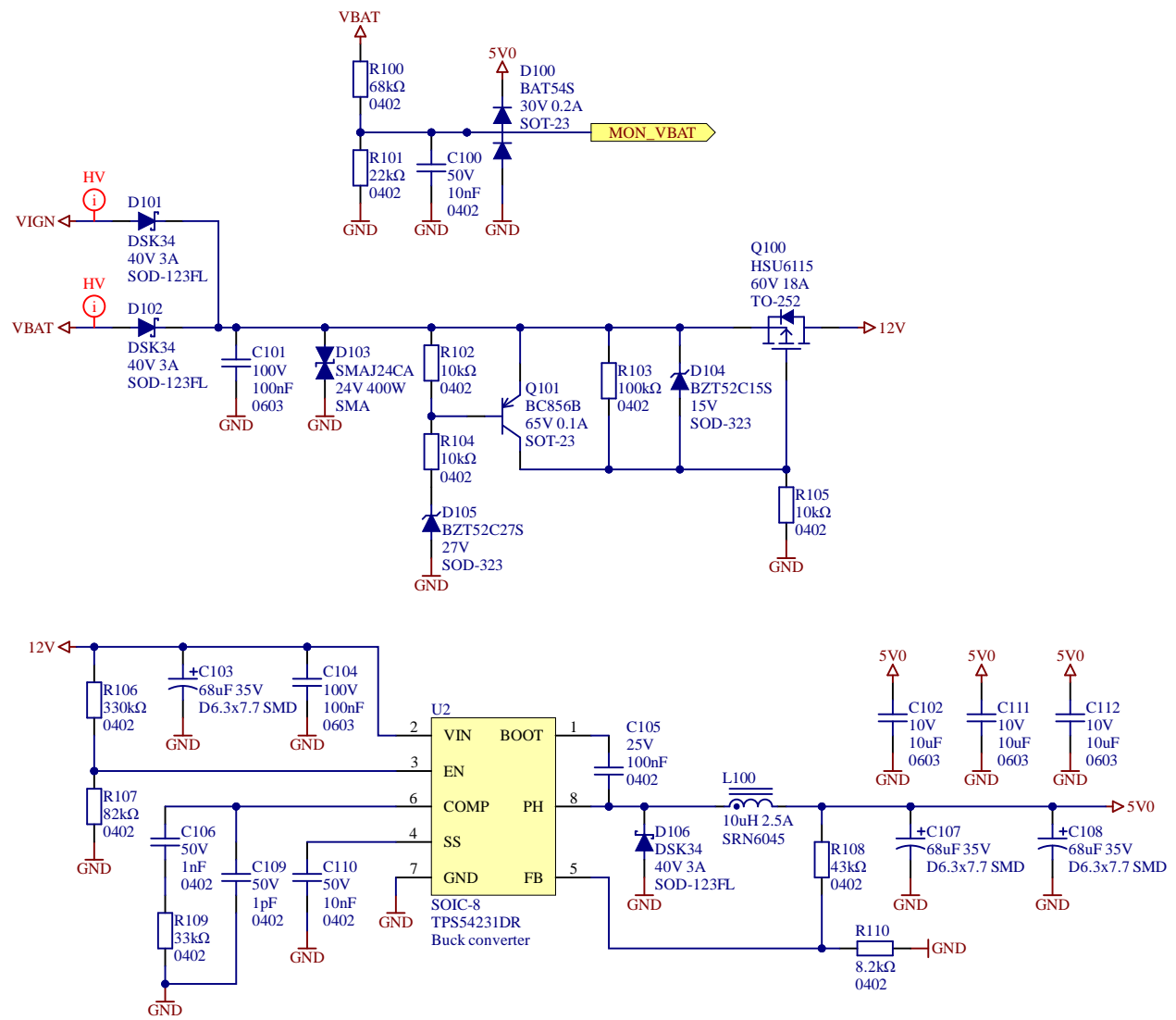
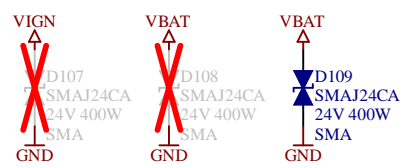
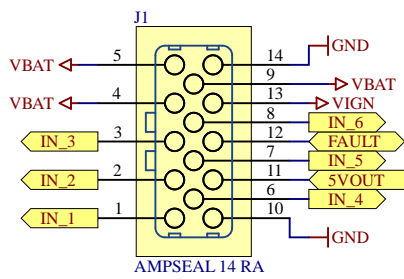
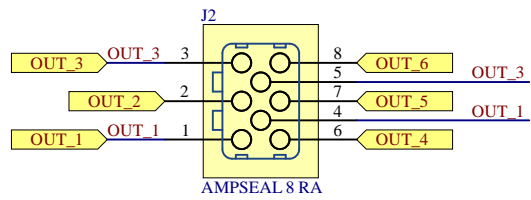

Title: Power				MicroRally
Project: sPDM-620				
PCB: r1	BOM: v1	Sheet 4 of 9	Size: A4	Engineer: Andis Zile
File: Power.SchDoc				Date: 10.04.2024

A

A

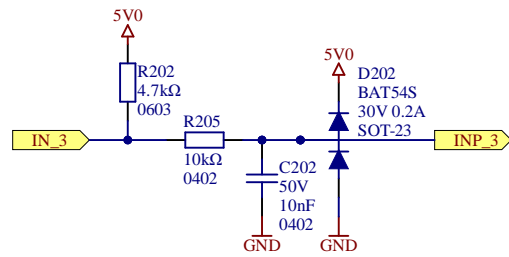
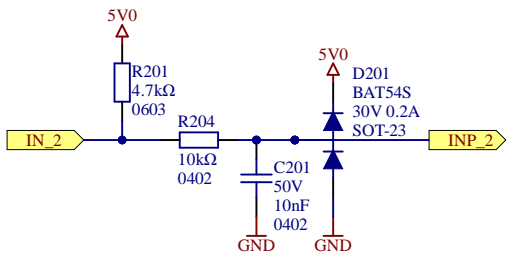
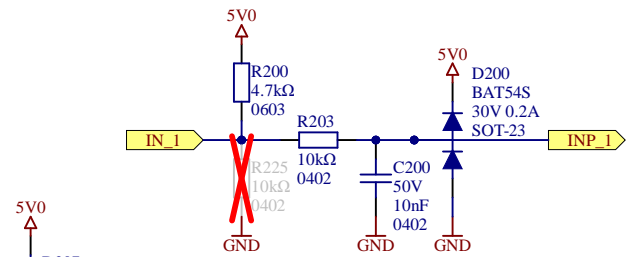

B

B

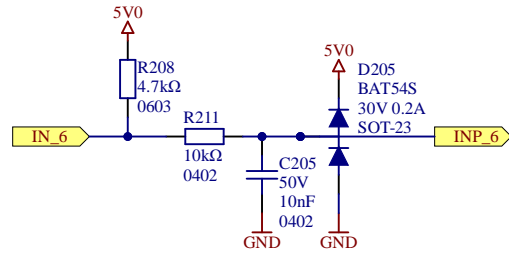
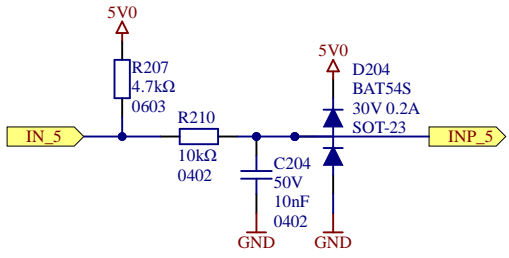
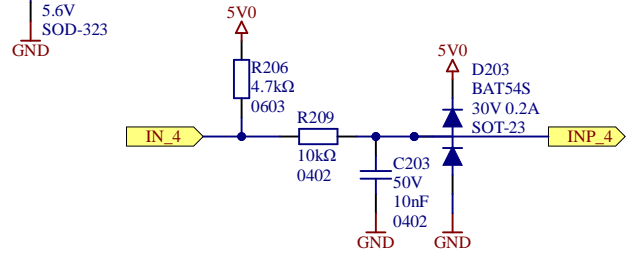

C

C

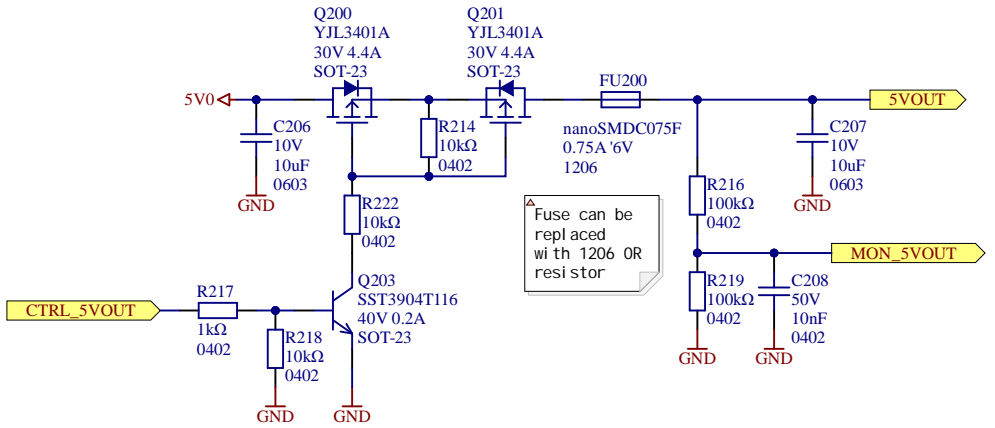
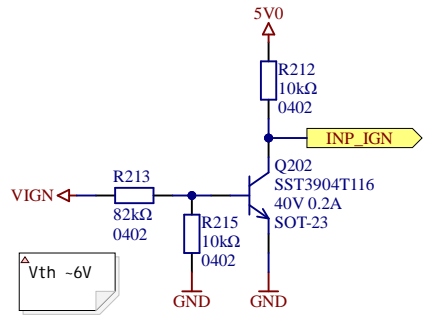

D

D

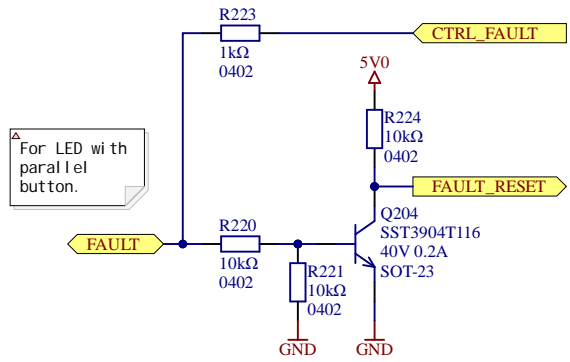

Title: Inputs				MicroRally
Project: sPDM-620				
PCB: r1	BOM: v1	Sheet 5 of 9	Size: A4	Engineer: Andis Zile
File: Inputs.SchDoc				Date: 10.04.2024

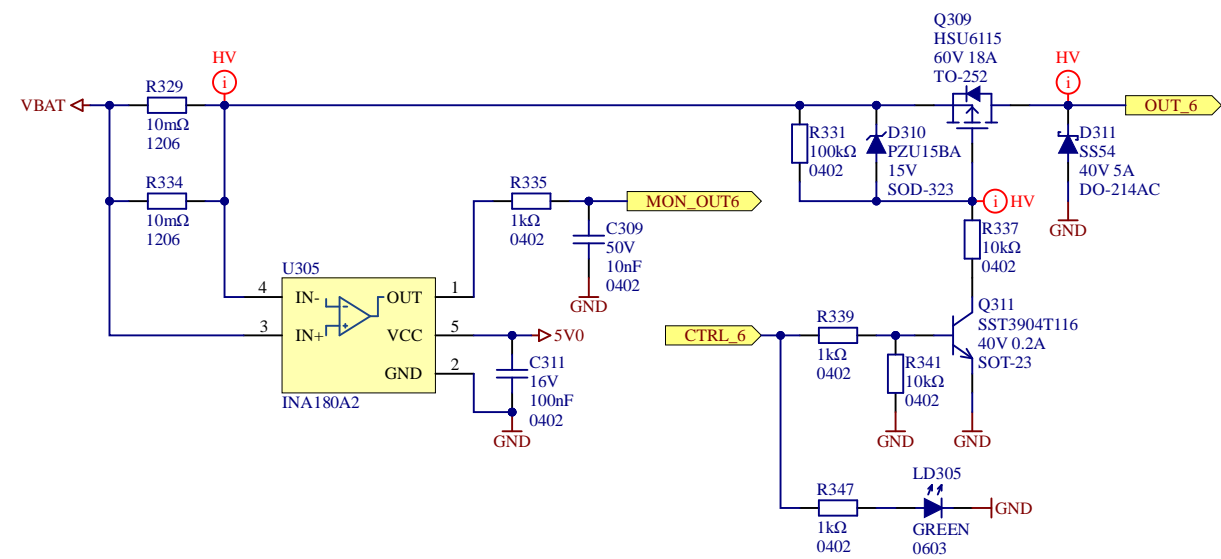
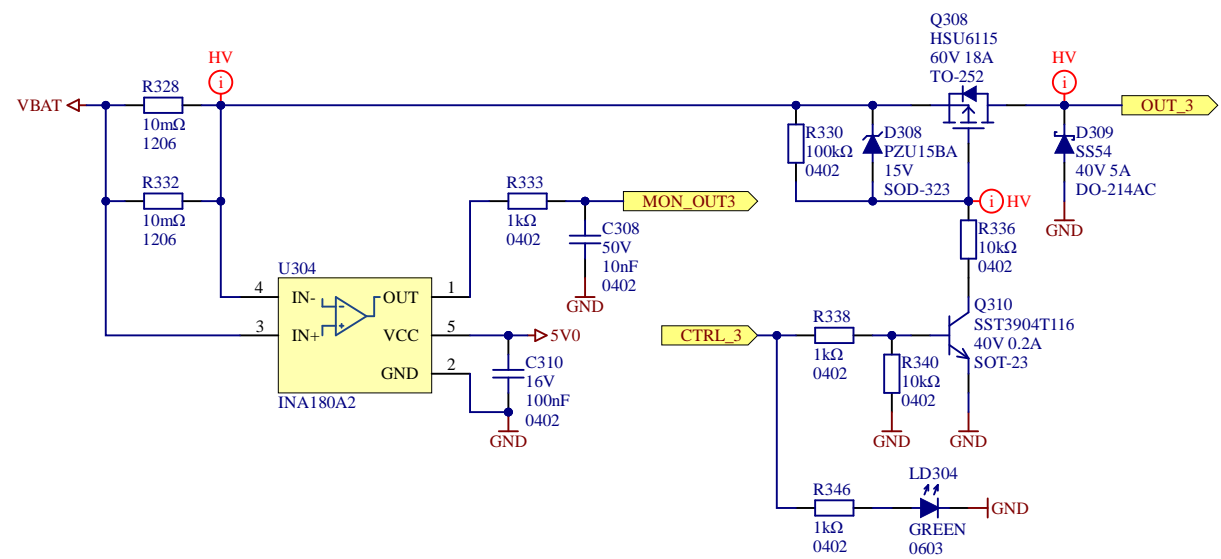
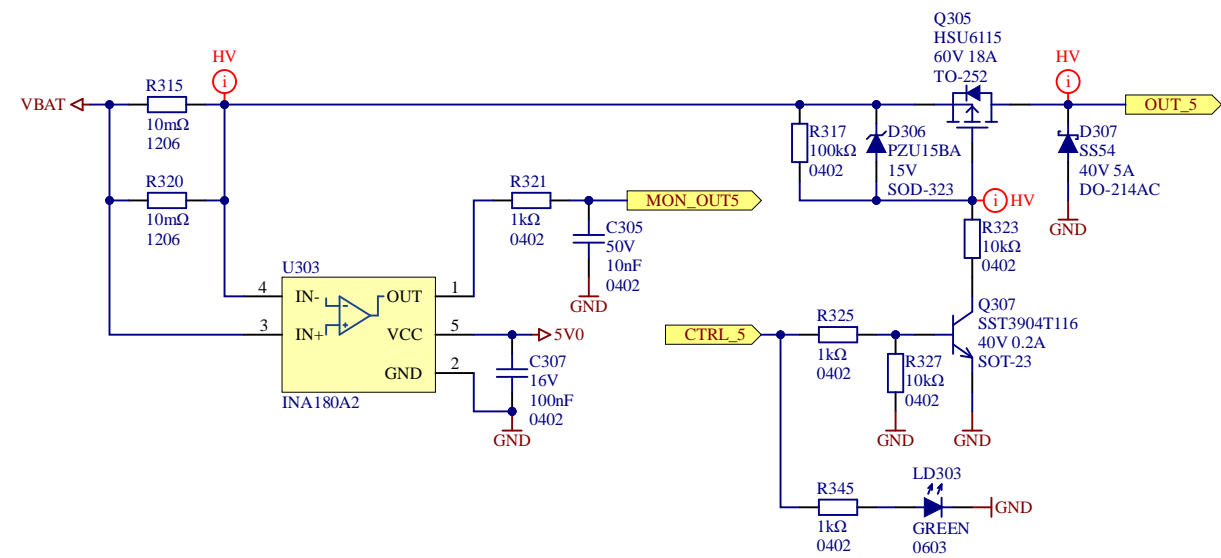
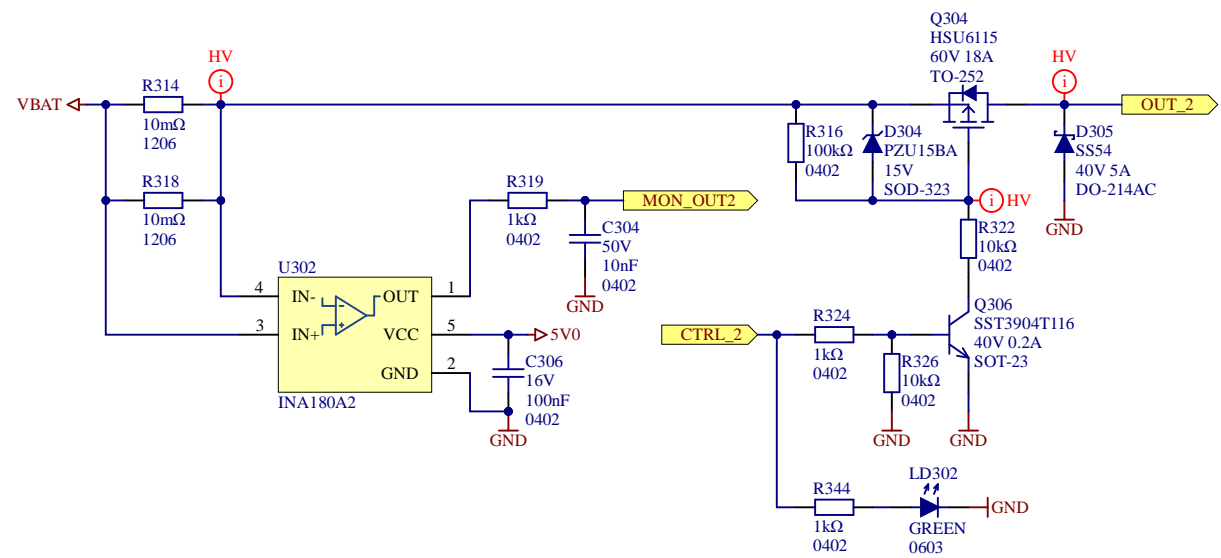
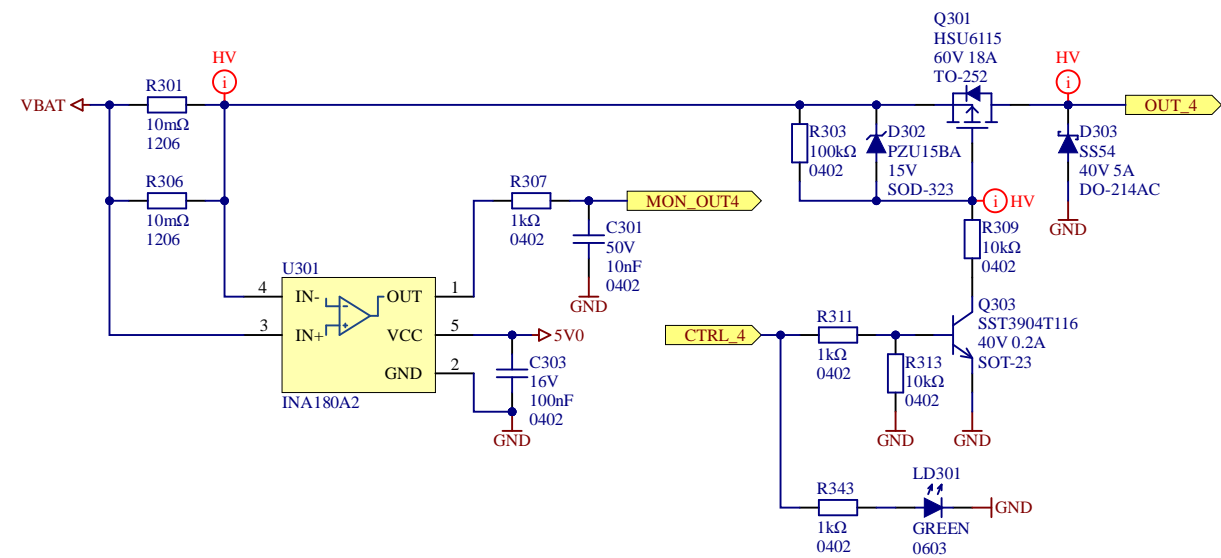
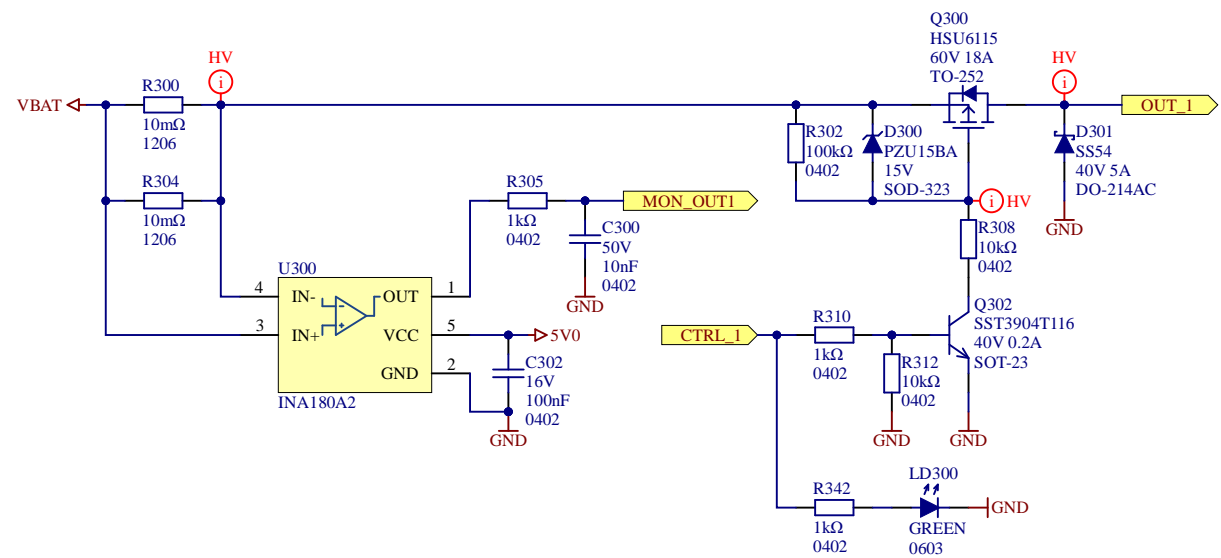

Title: Outputs				MicroRally
Project: sPDM-620				
PCB: r1	BOM: v1	Sheet 6 of 9	Size: A3	Engineer: Andis Zile
File: outputs.SchDoc				Date: 10.04.2024

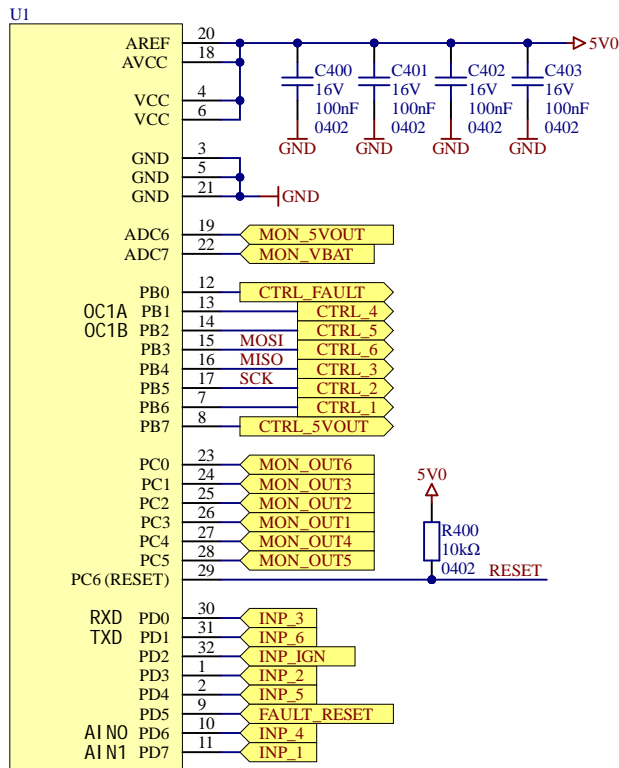

ATMEGA328P-AU  
AVR 8bit  
TQFP-32

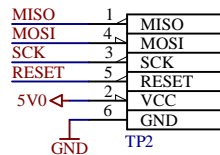

Pin	PORT	GPIO	Special	ADC	AIN	Timer 0	Timer 1	Timer 2	UART	I2C	SPI	INT	PCINT	Usage	Option
19				ADC6										5V Monitor	
22				ADC7										Battery voltage monitor	
12	PB0	OUT	CLKO					ICP1					PCINT0	Fault output	
13	PB1	OUT						OC1A					PCINT1	CH4 Control	PWM
14	PB2	OUT						OC1B					PCINT2	CH5 Control	PWM
15	PB3	OUT	MOSI					OC2A			SS		PCINT3	CH6 Control	
16	PB4	OUT	MISO								MISO		PCINT4	CH3 Control	
17	PB5	OUT	SCK								SCK		PCINT5	CH2 Control	
7	PB6	OUT	TOSC1/XTAL1										PCINT6	CH1 Control	
8	PB7	OUT	TOSC2/XTAL2										PCINT7	5V Output control	
23	PC0			ADC0									PCINT8	CH6 Current monitor	
24	PC1			ADC1									PCINT9	CH3 Current monitor	
25	PC2			ADC2									PCINT10	CH2 Current monitor	
26	PC3			ADC3									PCINT11	CH1 Current monitor	
27	PC4			ADC4							SDA		PCINT12	CH4 Current monitor	
28	PC5			ADC5							SCL		PCINT13	CH5 Current monitor	
29	PC6		RESET										PCINT14	ISP Reset	
30	PD0	IN											PCINT16	Input 3	UART
31	PD1	IN											PCINT17	Input 6	UART
32	PD2	IN											PCINT18	Enable input	
1	PD3	IN											PCINT19	Input 2	
2	PD4	IN											PCINT20	Input 5	
9	PD5	IN											PCINT21	Fault reset input	
10	PD6	IN			AIN0								PCINT22	Input 4	Comp+
11	PD7	IN			AIN1								PCINT23	Input 1	Comp-

Title: Controller				MicroRally
Project: sPDM-620				
PCB: r1	BOM: v1	Sheet 7 of 9	Size: A4	Engineer: Andis Zile
File: Controller.SchDoc				Date: 10.04.2024

PCB Sheet      4 Layer Stackup      Gerber Notes 1.0

H1      H2      H3

WEEE      PCB1 Article Number      PCB DM  
 H6      MR2403r1      H7

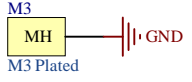
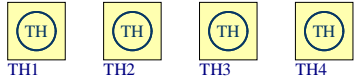

Title: Miscellaneous				MicroRally
Project: sPDM-620				
PCB: r1	BOM: v1	Sheet 8 of 9	Size: A4	Engineer: Andis Zile
File: Miscellaneous.SchDoc				Date: 10.04.2024

**Revision history**

PCB	BOM	Date	Fixed issue	Changes
R1	V1	2024-04-10		Initial design.

Title: Revision history				MicroRally
Project: sPDM-620				
PCB: r1	BOM: v1	Sheet 9 of 9	Size: A4	Engineer: Andis Zile
File: History.SchDoc				Date: 10.04.2024

A

A

B

B

C

C

D

D